

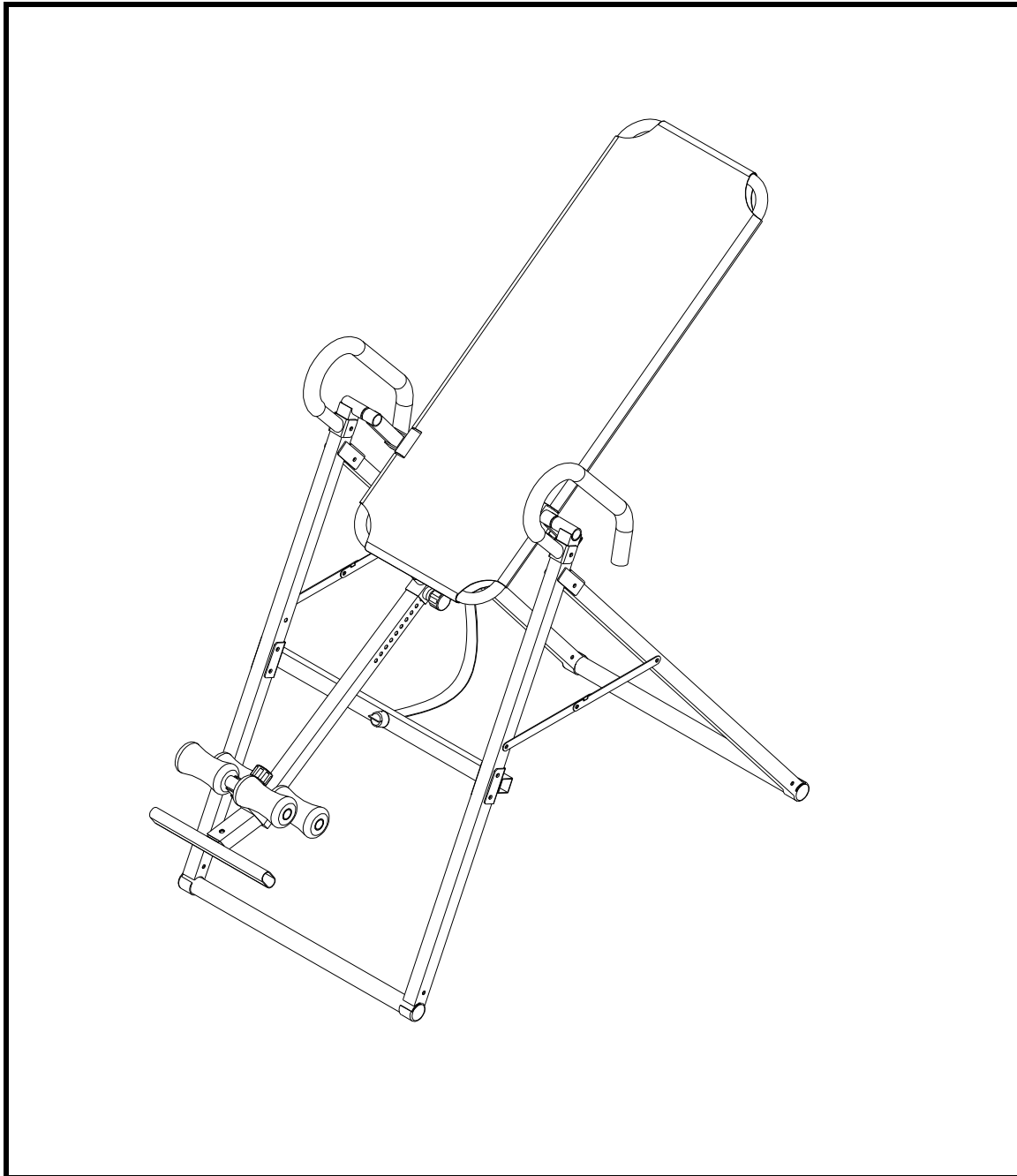

INVERSION TABLE

OWNER'S MANUAL



FN-10365

Table of Contents

<i>Important Safety Information</i>	2
<i>Exploded-View Assembly Drawing</i>	4
<i>Parts List</i>	5
<i>Assembly Instructions</i>	6
<i>How To Use Your Inversion Table</i>	9
<i>Care and Maintenance</i>	10
<i>Warranty</i>	12

Important Safety Information



WARNING: To reduce the risk of serious injury, read the following important precautions before using this Equipment. Please keep this manual in a safe place for easy reference.

1. It is important to read this entire manual before assembling and using the equipment. Everyone that uses the equipment needs to read this manual before being allowed to Invert.
2. Safe and effective use can only be achieved if the equipment is assembled, maintained and used properly. It is the Owner's responsibility to ensure that all users of the equipment are informed of all warnings and precautions prior to using the equipment.
3. Use the equipment only as described in this manual. Have a second person as a Safety Spotter as you learn how to invert on this machine. It is the responsibility of the owner to ensure that all users of the bench are adequately informed of all precautions.
4. Before starting any exercise program you should consult your doctor to determine if you have any medical or physical conditions that could put your health and safety at risk, or prevent you from using the equipment properly. Your doctor's advice is essential if you are taking medication that affects your heart rate, blood pressure or cholesterol level.
5. Be aware of your body's signals. Incorrect or excessive exercise can damage your health. Stop exercising if you experience any of the following symptoms: pain, tightness in your chest, irregular heartbeat, and extreme shortness of breath, lightheadedness, dizziness or feelings of nausea. If you do experience any of these conditions you should consult your doctor before continuing with your exercise program.
6. Always use the Safety Tether Strap. Before getting on the Machine tilt the table back to the Maximum angle and check where it will stop. Tighten the Safety Tether Strap to reduce the incline level.
7. Keep hands and feet away from all moving parts. Failure to do this can result in serious injury.
8. Keep children and pets away from the equipment. The equipment is designed for adult use only.
9. Use the equipment on a solid, flat level surface with a protective cover for your floor or carpet. To ensure safety, the equipment should have at least 2ft of free space all around it.
10. Before using the equipment always check that the nuts and bolts are securely tightened.
11. The safety of the equipment can only be maintained if it is regularly examined for damage and/or wear and tear.
12. Always use the equipment as indicated. If you find any defective components while assembling or checking the equipment, or if you hear any unusual noises coming from the equipment during use, stop immediately. Do not use the equipment until the problem has been rectified.
13. Wear suitable clothing while using the equipment. Avoid wearing loose clothing that may get caught in the equipment or that may restrict or prevent movement.
14. Care must be taken when lifting or moving the equipment so as not to injure your back. Always use proper lifting techniques and/or seek assistance if necessary.
15. Start with low angles of approximately 30 degrees. After you are comfortable on the Machine you can increase the angle as needed or directed by your Doctor. The maximum angle recommended is 60 degrees.
16. Spend no more than 5 minutes on the machine at any one time at least initially. THIS MEANS START SLOWLY.
17. Be conscious of yourself if you feel discomfort reduce the angle, if this does not give relief cease the activity.
18. Avoid using the INVERSION TABLE after meals.
19. Suitable for home use only. Maximum weight of user is 250lbs.
20. If you experience any problems or require any further assistance, please contact our Customer Service line on 818-357-2339.



WARNING: Before beginning this or any exercise program, consult your physician. This is very important for persons over the age of 35, or persons with pre-existing health problems. Read all instructions before using. Body+ and NuQuest International assumes no responsibility for personal injury or property damage sustained by or through the use of this product.



WARNING: The Following is a list of user conditions that need to be discussed with a doctor prior to inverting. (this is not an exhaustive list; it is intended only for reference).

- * pregnancy
- * hiatus hernia, ventral hernia
- * glaucoma, retinal detachment or conjunctivitis
- * high blood pressure, hypertension, recent stroke or transient ischemic attack
- * heart or circulatory disorders for which you're being treated
- * spinal injury, cerebral sclerosis, and acutely swollen joints
- * bone weakness(osteoporosis), recent unhealed fractures, medullar pins, and surgically implanted orthopedic supports
- * the use of anticoagulants, including high doses of aspirin
- * middle ear infection, and extreme obesity

If you have one or more of the above Conditions, you may still be able to invert. However, you must first obtain approval from your licensed physician.

Exploded Drawing

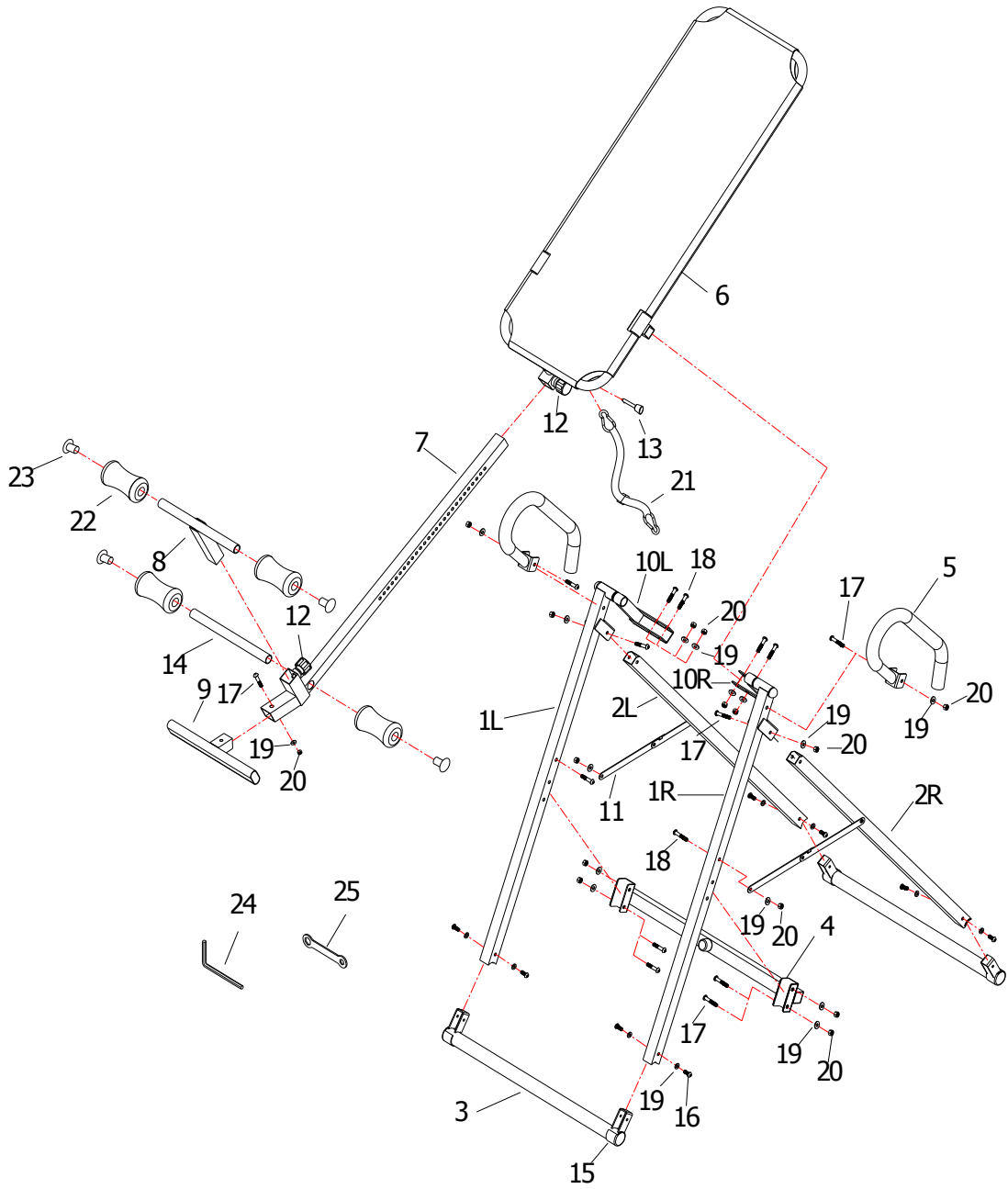

Parts List

NO.	DESCRIPTION	Q'TY
1LR	Front Main Frame	2
2LR	Rear Main Frame	2
3	Stabilizer Bar	2
4	Front Frame Cross Member	1
5	Handle bar	2
6	Backrest	1
7	Foot Support Arm	1
8	Upper Foot Rack	1
9	Footrest Bracket	1
10LR	Support Brackets	2
11	Folding Braces	2
12	Locking Knob	2
13	Bolt Pin	1
14	Lower Foot Rack	1
15	End Caps	4
16	Screw (Metric size 8-15mm long)	4
17	Screw (Metric size 8-50mm long)	9
18	Screw (Metric Size 8-45mm long)	6
19	Flat washer (8mm dia.)	23
20	Nylon nut (Metric size 8)	15
21	Safety Belt	1
22	Foam Tubes	4
23	End Cap	4
24	Inner Hex Wrench	2
25	Tool	1
26	Manual	1

Assembly Instructions

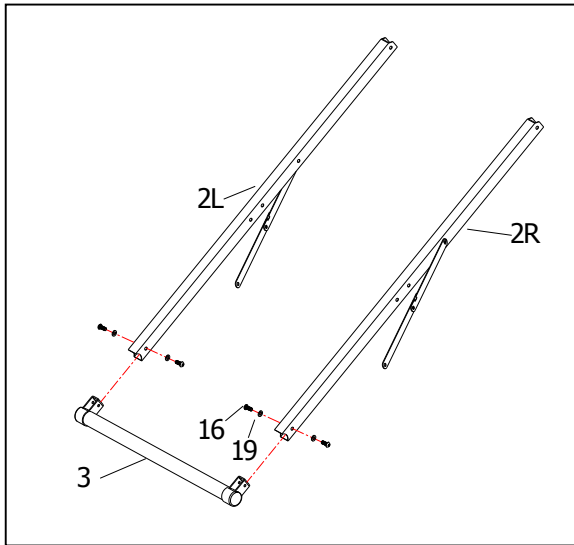

Step 1:

Assemble the Stabilizer Bar (3) to the left Rear Main Frame (2L) and right Rear Main Frame (2R) by using 2 sets of Screws (16) and Flat Washers (19).

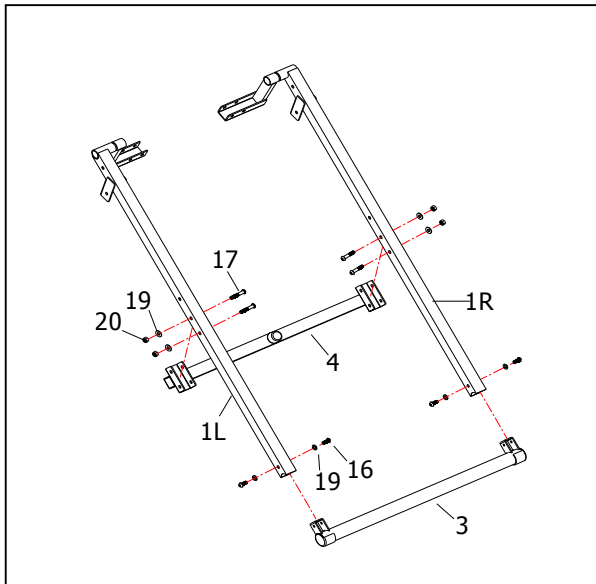

Step 2:

Assemble the second Stabilizer Bar (3) to the left Front Main Frame (1L) and right Front Main Frame (1R) by using 2 sets of Screws (16) and Flat Washer (19).

Assemble the Front Frame Cross Member (4) on left & right side of Front Main Frame by using 4 sets of Screws (17) Flat Washers (19) and Nylon Nuts (20).

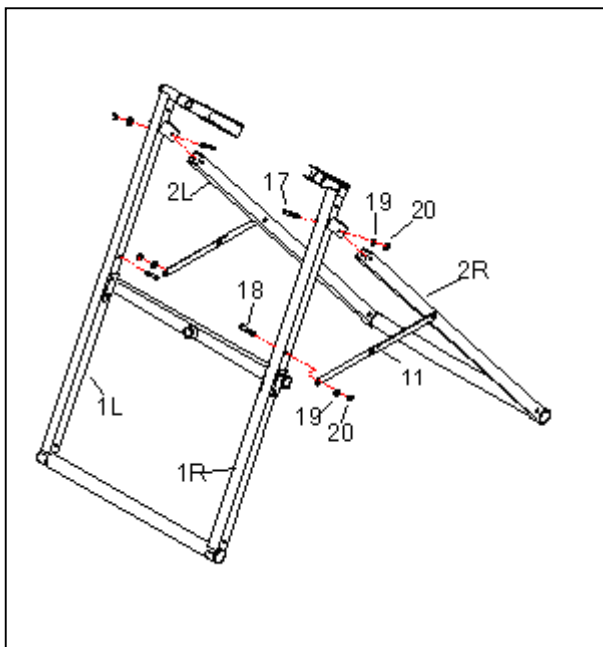

Step 3:

Insert Rear Main Frame assembly from step 1 into swivel brackets located at the open end of the Front Main Frame. Attach by using 2 sets of Screws (17) Flat Washers (19) and Nylon Nuts (20) each. Next attach the folding braces (19) on left & right the Rear Main Frame to the mounting brackets of the Front Main Frame by using 2 sets of Screws (18) Flat Washers (19) and Nylon Nuts (20).

Assembly Instructions: (continued)

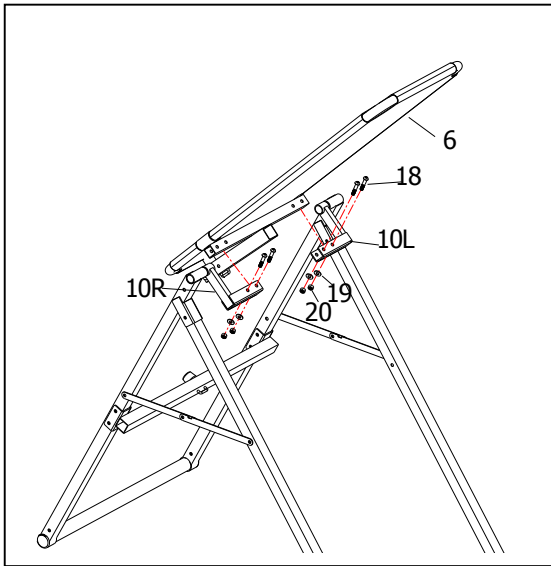

Step 4:

Assemble the Backrest (6) to the left & right Support Brackets (10L and 10R) by using 4 sets of Screws (18), Flat Washers (19) and Nylon Nuts (20).

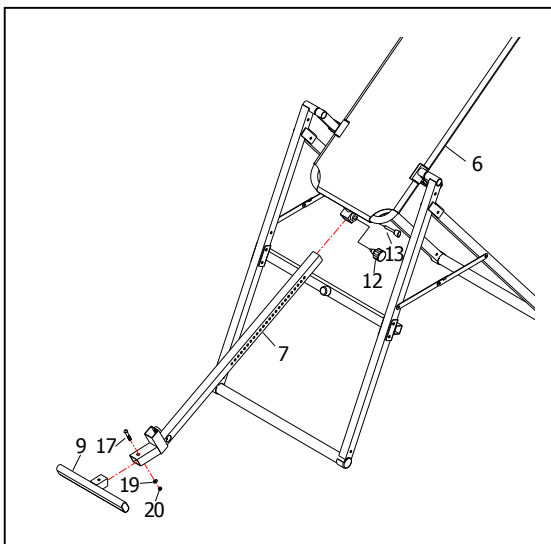

Step 5:

Remove the Locking Knob (12) and insert the Foot Support Arm (7) into the Backrest bracket. Position as per size available (see the "Using your Inversion Table" section) then tighten the Locking Knob (12), insert Bolt Pin (13). Insert Footrest Bracket (9) into the end of the Foot Support Arm (7) and attach it by using 1 set of Screw (17), Flat Washer (19) and Nylon Nut (20).

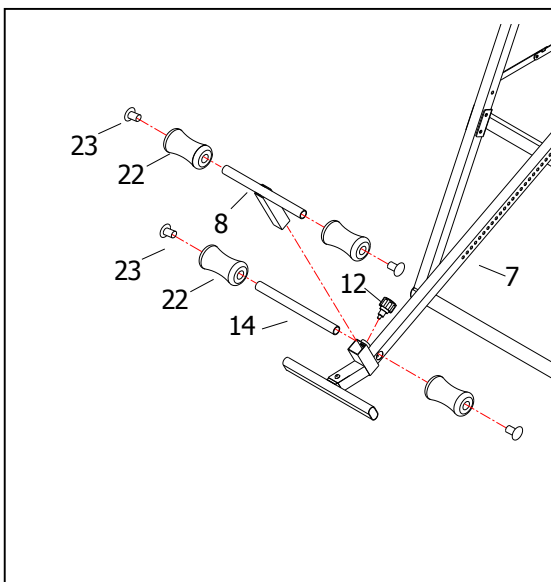

Step 6:

Insert the Upper Foot Rack (8) into the upright bracket as shown (adjust to suitable hole position as per user's foot size). Secure by using Locking Pin (12). Place the Foam Tubes (22) over both sides of the Rack arms and hold in place using the end caps (23). Insert the Lower Foot Rack (14) into the hole in the Foot Support Arm (7). Place the Foam Tubes (22) over both sides of the Rack arms and hold in place using the end caps (23).

Assembly Instructions: (continued)

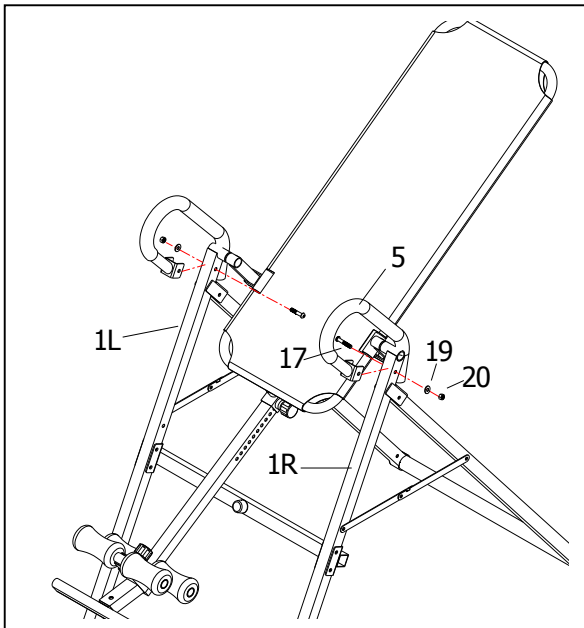

Step 7:

Attach Handle Bar (5) to the left side of the Front Main Frame by using 1 set of Screw (17), Flat Washer (19) and Nylon Nut (20). Repeat for the right side.

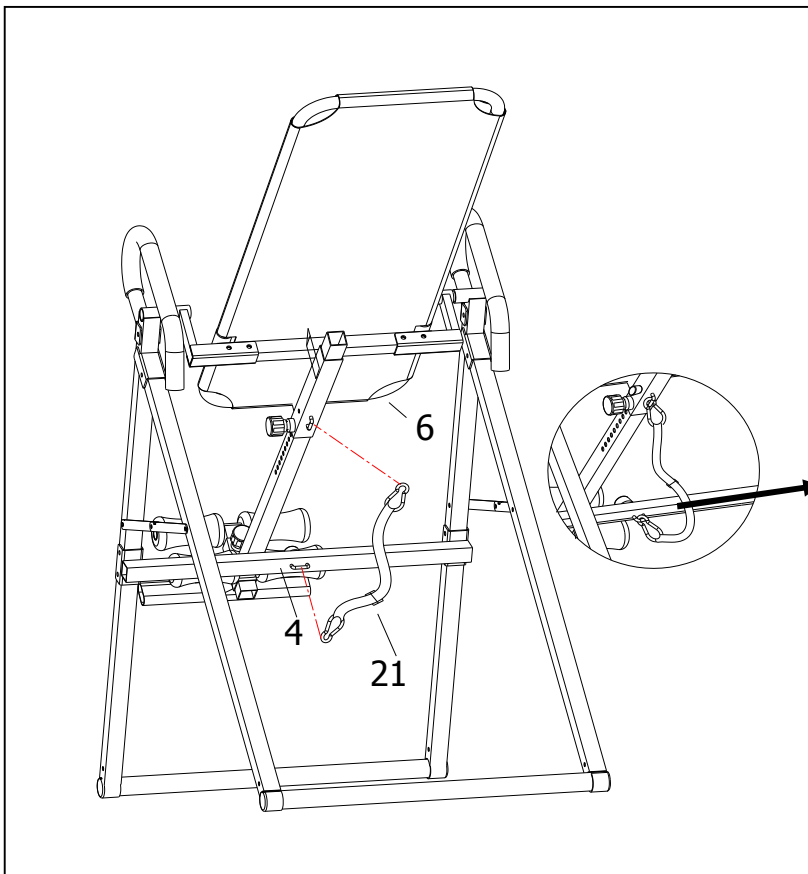

Step 8:

Attach one end of Safety Belt (21) to the inner Ring on the back of Backrest (6) and attach the opposite end to the inner ring on back of the Front Frame Cross Member (4). Adjust to a suitable length before operating.

How to Use Your Inversion Table

WARNING: TO BE PERFORMED PRIOR TO EACH USE!!

Adjust the height on the foot support arm to your to height in inches. Make sure the Safety Tether Strap is securely attached to both the Table and the Frame. **THE SAFETY TETHER STRAP IS PRE-SET AT THE FACTORY FOR 25 DEGREES OF INCLINE. IT IS HIGHLY RECOMMENDED THAT YOU BEGIN YOUR EXERCISE ROUTINE AT THAT SETTING.** Tilt the table back with no one on the Machine to check the Maximum Angle. Tighten or Loosen the Safety Tether Strap as needed to adjust the Maximum Angle. Remember it is always safer to start with an angle not exceeding 30 degrees until you are comfortable inclining.

Balancing Your Inversion Table

The inversion table is a very sensitively balanced device. It responds to very slight changes in weight distribution, so it is very important to make sure that the table is balanced properly. To do this, mount the machine after you have made the adjustments in the above warning, lock your ankles into the heel holders, and lay back with your hands at your sides. Slowly place you hands across you chest. This will cause the table to invert to a Parallel Position. While in this position, your head should still be slightly above your feet. If your feet are above head, dismount and adjust the height to the next longest position and repeat until a balanced position is achieved.

Using Your Inversion Table

1. Start by locking your feet into place as described above. Slowly lay onto the backrest with your hands at your sides. (diagram 1)
2. Keeping your hands close to your body and begin to raise your arms slowly allowing the table to rotate backward. Stop, or lower your arms to control and slow down the downward rotation of the table.(diagram 2)
3. Raise your arms until they are over your head. At this point, the inversion table will be as far back as Safety Tether Strap will allow it to go. (diagram 3)
4. Return to the upright position by slowly moving your hands back down to your thighs. (diagram 4)
5. Be careful not to put your hands or feet in the way of any moving parts. Use the Handle Bars for support as needed.
6. It is recommended that the inversion table be used for five or ten minutes each morning, and again each evening.

1.



2.



3.



4.



Suggestions for First Time Users

1. Begin slowly: invert only to a maximum 25 degrees. Stay inverted only as long as you are comfortable and never exceed 5 minutes. Return upright slowly. **(SEE WARNING: TO BE PERFORMED PRIOR TO EACH USE)**
2. Make gradual changes; increase the angle only if it is comfortable. Increase the angle only a few degrees at a time. Increase the time of use 1-2 minutes up to a Maximum 10 minutes over a period of weeks. Add stretching and light exercise only after you are comfortable with inversion.
3. Listen to your body, come up slowly, dizziness after a session means you returned to quickly. Allow appropriate time to pass after eating before using the table.. If you get nauseous, return to the non-inverted position.
4. Using slow movements while inverted encourages blood, circulation. Movement may be accomplished by either rhythmic traction or light exercise. Never perform strenuous exercises while inverted. Limit partial inversion without movement to one or two minutes. Limit full inversion with no movement to only a few seconds.

Invert regularly: we recommend two or three times a day depending upon your current condition. Try to schedule inverting for the same time each day.

Care And Maintenance

1. Check before the Inversion Table is first used and again at regular intervals that all screws, bolts, nuts and other connections are securely fastened to ensure that your training equipment is in safe operating condition.
2. Periodically check all moving parts, upholstery and grips for signs of wear or damage. If there is a problem or replacement parts are necessary, STOP USING THE EQUIPMENT and immediately contact your local retailer. DO NOT use the EQUIPMENT until repaired.
3. Lubrication of all moving parts is essential to the longevity and optimal performance of your Inversion Table. We recommend the use of a clear aerosol, silicone or Teflon spray. Do not use oil based lubricants as they will attract dust, dirt and grime and will eventually gum up and erode joints or sliding parts.
4. As needed, upholstery may be cleaned with a mild solution of soap and water. Regular use of a vinyl treatment will add to the life and appearance of your upholstery.
5. All chrome plated surfaces should be cleaned regularly to prolong the life and luster of the finish. Wipe the machine down with a commercial grade or automotive type chrome polish.
6. Check welds for signs of cracks. Discontinue use immediately if cracks are found.
7. Failure to perform routine maintenance could result in personal injury and/or equipment damage.

Safety Notice

Not recommended for use without competent adult supervision.

It is important to read this entire manual before assembling and using the equipment. Safe and effective use can only be achieved if the equipment is assembled, maintained and used properly. It is your responsibility to ensure that all users of the equipment are informed of all warnings and precautions.

If you experience any problems or require any further assistance, please contact our Customer Service line on 818-357-2339.

Limited USA Warranty

NuQuest International Inc. Warrants iGym® Fitness Equipment to be free from defects in workmanship and material under normal use and service conditions. Parts are warranted for one hundred and eighty (180) days after the date of purchase.

This warranty extends only to the original purchaser. NuQuest Intl's obligation under this warranty is limited to replacement parts. This warranty does not extend to any product or damage to a product caused by or attributable to freight damage, abuse, misuse, improper or abnormal usage, for commercial or rental purposes; or products used as store display models. No other warranty beyond that specifically set forth above is authorized by NuQuest International.

NuQuest International is not responsible or liable for indirect, special or consequential damages arising out of or in connection with the use or performance of the product or damages with respect to any economic loss, loss of property, loss of revenues or profits, loss of enjoyment or use, costs of removal or installation or other consequential damages of whatsoever nature.

Some states do not allow the exclusion or limitation of incidental or consequential damages. Accordingly, the above limitation may not apply to you. The warranty extended hereunder is in lieu of any and all other warranties and any implied warranties of merchantability or fitness for a particular purpose is limited in its scope and duration to the terms set forth herein. Some states do not allow limitations on how long an implied warranty lasts. Accordingly, the above limitation may not apply to you.

This warranty gives you specific legal rights. You may also have other rights which vary from state to state.

Congratulations on your purchase of fitness equipment. You may register your product with the form below or simply go to our website at:

http://www.nuquestintl.com/Warranty_Page.html.

Registering your product makes it easier for us to help you obtain service for your product so don't delay and register today.

Registration form can be sent to:

Nuquest International Inc.
19360 Rinaldi St. Suite 332 Porter Ranch, CA 91326

Product Warranty and Registration Card

Your name:

Address:

City:

State: * Zip Code:

Email:

Product Name

Product Number

Purchased at?

Date of Purchase



Nuquest International Inc.

19360 Rinaldi St. Suite 332 Porter Ranch, CA 91326

www.nuquestintl.com

iGym is a trademark of and used under license from Powersky Century Holdings Ltd.

All right reserved, unauthorized duplication is a violation of law